

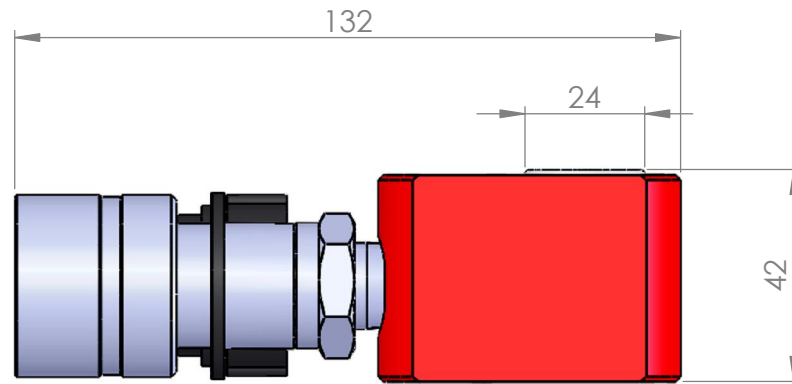
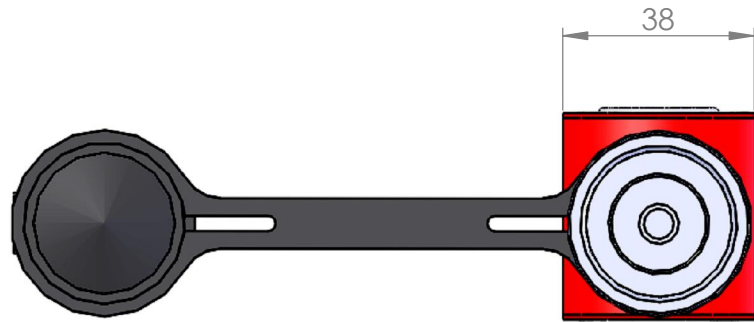

DRAWING CHANGE

1
132
143
154
165
176
187
198
209
2110
2211
2312
24

INC REV. DRAWINGS AT REVISION #.# ARE VALID FOR USE WITH DOCUMENTATION FOR REVISION #

**Hi-Force**
HYDRAULIC TOOLSPROSPECT WAY, DAVENTRY
NORTHANTS. NN11 8PLTITLE:
LOW HEIGHT PAD CYLINDERTHIS DRAWING IS THE SOLE PROPERTY OF HI-FORCE LTD.
AND MUST NOT BE LOANED, COPIED OR
USED IN ANY WAY WITHOUT THE WRITTEN CONSENT OF THE Co.DRAWN
DATE
CHKD
MM
24/04/2015MATERIAL:
FINISH:

REMARKS

UNLESS SPECIFIED
OTHERWISE, M/C FINISH
Ra 1.6 µm**DO NOT SCALE**ALL DIMS ARE IN mm AND INCLUDE ANY
SURFACE TREATMENTS.
TOLERANCES (UNLESS SPECIFIED OTHERWISE):
LINEAR DIMS ±0.25
ANGULAR DIMS ±0.5°
COAXIAL DIAMS TO BE CONCENTRIC TO WITHIN
0.05 T.I.R. REMOVE ALL BURRS AND SHARP EDGES

COMPONENT DRG NO.

HPS51**SHT 1 OF 1 SHTS**