

285B Series Air Impact Wrench Exploded Diagram

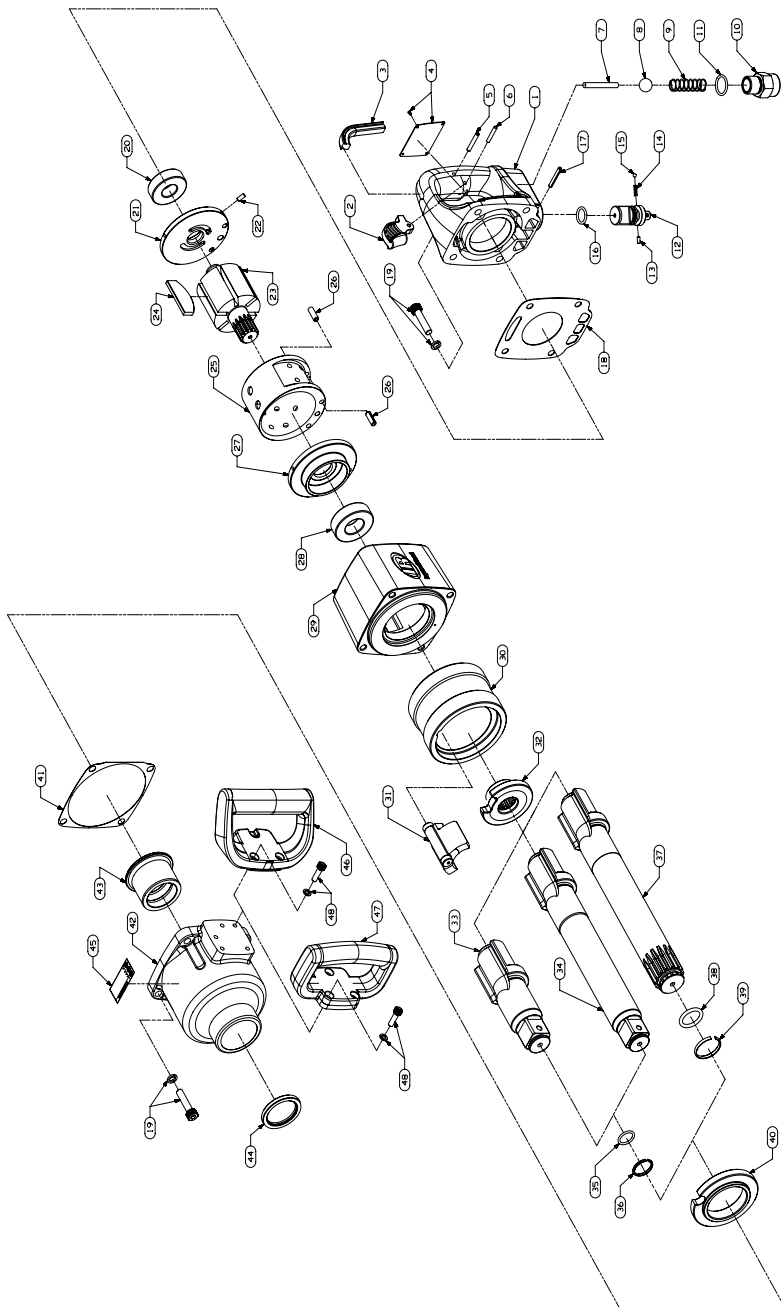

(Dwg. 16578726)

285B Series Air Impact Wrench Parts List

Item	Part Description	Part Number	Item	Part Description	Part Number
1	Trigger Handle Assembly	285B-A92A	27	Front End Plate	285B-11
2	Trigger	285B-93A	28	Front Rotor Bearing	285B-96
3	Slot Cover	285B-438	29	Motor Housing	285B-40
4	Nameplate and 4 rivets	285B-A301	30	Hammer Frame	285B-703
5	Stop Pin	285B-439	31	Hammer	285B-724
6	Pin, Spring	285B-437	32	Hammer Cam	285B-721
7	Plunger, Throttle Valve	285B-302	33	Anvil Assembly, Std. Length	285B-A726
8	Throttle Valve	285B-50	34	Anvil Assembly, 6" extended Length	285B-A726-6
9	Spring, Throttle Valve	285B-51	35	O-Ring	BBFM-557
10	Inlet Bushing Assembly	285B-A565	36	Retainer Ring	910E5-918
11	O-Ring	285B-566	37	6" Extended #5 Spline Anvil	285B-A514-6
12	Reverse Valve Assembly	285B-A329	38	O-Ring	285B-S-557
13	Stop Pin	285B-332	39	Retaining Ring	285B-S-918
14	Spring	285B-334	40	Side Plate	285B-706
15	Ball	285B-333	41	Hammer Case Gasket	285B-36
16	Reverse Valve Seal	285B-338	42	Hammer Case Assembly	285B-A727
17	Pin, Spring	285B-120	43	Hammer Case Bushing	285B-641
18	Gasket, Handle	285B-283	44	Oil Seal	285B-642
19	Handle Cap Screw and washer (Set of 8)	285B-A638	45	Warning Label	Warning-2-99
			46	Dead Handle (Angled) with screws	285B-A48-6
20	Rear Rotor Bearing	285B-24	47	Dead Handle (Straight) with screws	285B-A48
21	End Plate with alignment pin	285B-A12	48	Screw and Washer (3)	
22	Pin, Spring			Tune up kit (includes items 3,7,8, 9,11,13,14,15,16,17,18,20,24,28,35, 36, 41 & 44)	285B-TK1
23	Rotor	285B-53			
24	Vane Pack (Set of 6)	285B-42-6			
25	Cylinder and alignment pins	285B-A3			
26	Pin, Spring (2)				

Parts and Maintenance

When the life of the tool has expired, it is recommended that the tool be disassembled, degreased and parts be separated by material so that they can be recycled.

Tool repair and maintenance should only be carried out by an authorized Service Center.

Refer all communications to the nearest **Ingersoll Rand** Office or Distributor.

Related Documentation

For additional information refer to:

Air Impact Wrench Product Safety Information Manual Form 04580916.

Air Impact Wrench Product Information Manual Form 80160666.

Manuals can be downloaded from www.irtools.com.