



FY 2.15/16 UTF Square flanged ball bearing unit with set screw locking, cast iron housing, ISO

Square flanged ball bearing unit with set screw locking, cast iron housing, ISO

These square flanged ball bearing units are compliant with ISO standards. They consist of an insert bearing, with an extended inner ring and set screw locking, and are suitable for applications where the direction of rotation is constant or alternating. The bearing is mounted in a cast iron housing, which can be bolted to a machine wall or frame. Ball bearing units can accommodate moderate initial misalignment, but normally do not permit axial displacement.

- Resist high levels of contamination
- Designed for high temperatures and speeds
- Accommodate relatively heavy loads
- Cost-effective

Overview

Dimensions

Shaft diameter	74.613 mm
Housing overall width	65 mm
Width, total	87.3 mm
Centre distance between bolt holes	152.5 mm
Bearing width, total	73.3 mm

Performance

Basic dynamic load rating	66.3 kN
Basic static load rating	49 kN
Limiting speed	2 600 r/min
Note	Limiting speed with shaft tolerance h6

Properties

Housing type	Flanged
Flanged housing type	Square
Number of bolt holes for fasteners	4
Fastening bolt hole type	Plain
Retaining feature, inner ring	Set screws
Bore type	Cylindrical
Rubber seating ring	Without
Material, housing	Cast iron

Material, bearing	Bearing steel
Coating	Without
Sealing, bearing	Seal and flinger on both sides
Sealing type	Contact, standard
Sealing, unit	Without
Lubricant	Grease
Relubrication hole	With
Grease fitting	With

Technical Specification

Compliance with standard	ISO with boundary dimension deviations
Purpose specific	For material handling applications
Material, housing	Cast iron
Sealing, bearing	Seal and flinger on both sides
Sealing type, bearing	Contact, standard
Sealing, unit	Without
Coating	Without

Dimensions

d	74.613 mm	Bore diameter
d_1	≈ 92.05 mm	Outer diameter of inner ring
A	65 mm	Overall width
A_1	19 mm	Flange width
B	73.3 mm	Width of inner ring
B_1	73.3 mm	Overall bearing width
B_4	12 mm	Distance from locking device side face to thread centre
D_{b1}	155 mm	Top external diameter
D_{b2}	162 mm	Base external diameter
J	152.5 mm	Distance between attachment bolts
L	197 mm	Overall length
N	22 mm	Diameter of attachment bolt hole
s_1	46.3 mm	Distance from locking device side face to raceway centre
T	87.3 mm	Overall unit width

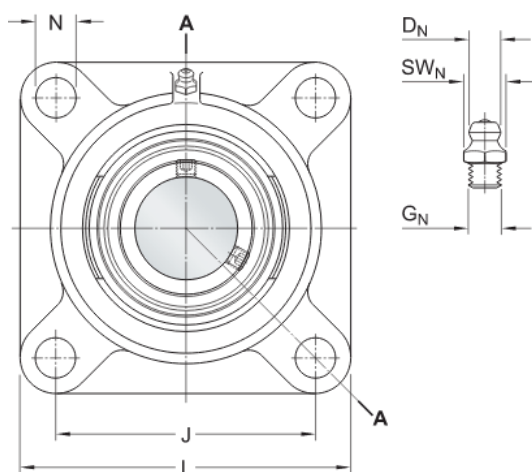

Threaded hole

R_G	1/8-27 NPT	Housing thread for grease fitting
R_1	41 mm	Axial position of the housing thread

Grease fitting

D_N	6.579 mm	Diameter of head sphere of grease fitting
SW	11.113 mm	Hexagonal key size for the grease fitting
G_N	1/8-27 NPT	Thread of grease fitting

Calculation data

Basic dynamic load rating	C	66.3 kN
Basic static load rating	C_0	49 kN
Fatigue load limit	P_u	2.04 kN
Limiting speed		2 600 r/min
		Limiting speed with shaft tolerance h6

Mass

Mass bearing unit	6.35 kg
-------------------	---------

Mounting information

Set screw	G_2	7/16-20 UNF
Hexagonal key size for set screw		5.556 mm
Recommended tightening torque for set screw		28.5 N·m
Recommended diameter for attachment bolts, mm	G	20 mm
Recommended diameter for attachment bolts, inch	G	0.75 in

Terms and conditions

By accessing and using this website / app owned and published by AB SKF (publ.) (556007-3495 · Gothenburg) ("SKF"), you agree to the following terms and conditions:

Warranty Disclaimer and Limitation of Liability

Although every care has been taken to assure the accuracy of the information on this website / app, SKF provides this information "AS IS" and DISCLAIMS ALL WARRANTIES, EXPRESS OR IMPLIED, INCLUDING, BUT NOT LIMITED TO, IMPLIED WARRANTIES OF MERCHANTABILITY AND FITNESS FOR A PARTICULAR PURPOSE. You acknowledge that your use of this website / app is at your sole risk, that you assume full responsibility for all costs associated with use of this website / app, and that SKF shall not be liable for any direct, incidental, consequential, or indirect damages of any kind arising out of your access to, or use of the information or software made available on this website / app. Any warranties and representations in this website / app for SKF products or services that you purchase or use will be subject to the agreed upon terms and conditions in the contract for such product or service. Further, for non-SKF websites / apps that are referenced in our website / app or where a hyperlink appears, SKF makes no warranties concerning the accuracy or reliability of the information in these websites / apps and assumes no responsibility for material created or published by third parties contained therein. In addition, SKF does not warrant that this website / app or these other linked websites / apps are free from viruses or other harmful elements.

Third Party Services

When viewing YouTube content via the SKF website(s) (i.e. using YouTube API Services), you agree to be bound by the YouTube Terms of Service.

Copyright

Copyright in this website / app copyright of the information and software made available on this website / app rest with SKF or its licensors. All rights are reserved. All licensed material will reference the licensor that has granted SKF the right to use the material. The information and software made available on this website / app may not be reproduced, duplicated, copied, transferred, distributed, stored, modified, downloaded or otherwise exploited for any commercial use without the prior written approval of SKF. However, it may be reproduced, stored and downloaded for use by individuals without prior written approval of SKF. Under no circumstances may this information or software be supplied to third parties.

This website /app includes certain images used under license from Shutterstock, Inc.

Trademarks and Patents

All trademarks, brand names, and corporate logos displayed on the website / app are the property of SKF or its licensors, and may not be used in any way without prior written approval by SKF. All licensed trademarks published on this website / app reference the licensor that has granted SKF the right to use the trademark. Access to this website / app does not grant to the user any license under any patents owned by or licensed to SKF.

Changes

SKF reserves the right to make changes or additions to this website / app at any time.