

## HHA - SINGLE ACTING HOLLOW PISTON ALUMINIUM CYLINDERS



Capacities from 18 to 52 tonnes

Stroke lengths from 51 to 105mm

Working pressure 700 Bar

B

The HHA range of single acting hollow piston aluminium cylinders are specifically designed for applications where weight and ease of positioning are of prime importance. Similar in design to the HHS range, the HHA cylinder models have a hollow piston to enable a rod or cable to be passed through the entire cylinder length making it suitable for applications where a pulling force is required. All models are supplied with a hard anodised, wear resistant, piston rod and cylinder body and a steel cylinder base protection plate. Available lifting capacities range from 18 to 52 tonnes, at maximum working pressure of 700 Bar.



Please Note.....

Aluminum cylinders offer the benefit of greatly reduced weight compared to conventional steel cylinders. However, due to the inherent nature of the material, are not recommended for use in high cycle production applications. The recommended life cycle is estimated at approximately 5000 operations at maximum pressure, which in most lifting and maintenance applications represents a more than acceptable period of usage.

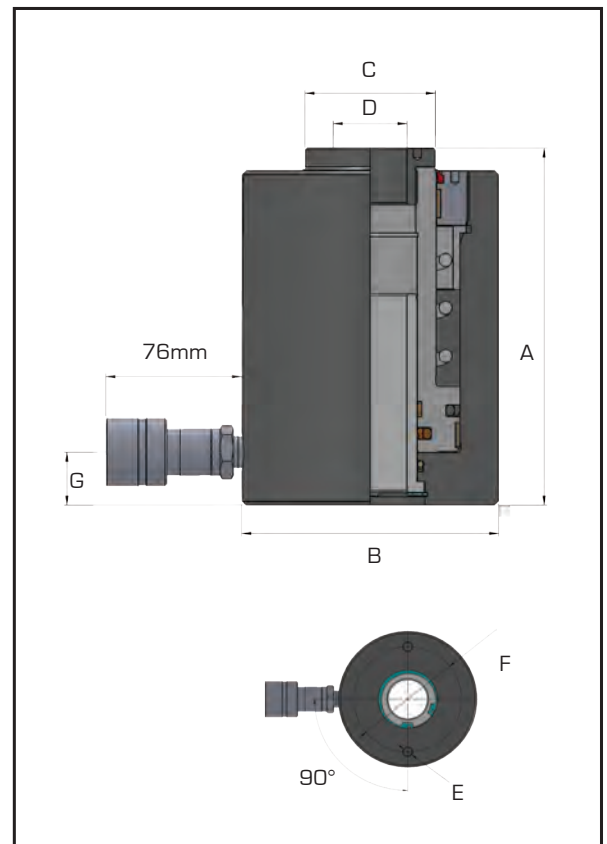

Model number	Capacity tonnes	Stroke mm	Oil cap. cm <sup>3</sup>	Cyl. eff. area cm <sup>2</sup>	Weight kg
<b>HHA182</b>	18	51	129	25.2	3.4
<b>HHA372</b>	37	51	266	52.1	7.0
<b>HHA504</b>	52	105	765	72.8	13.2

Dimensions in mm (unless otherwise stated)						
A	B	C	D	E	F	G
171	98	45	26	M8x10	66.0	22
189	136	69	39	M10x15	105.0	28
276	160	79	51	M10x15	130.2	35